

RESPIRONICS®

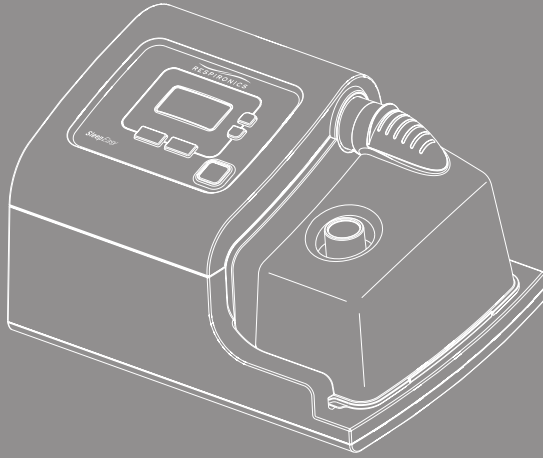

SleepEasy®

User Manual

Would you like a free travel bag for your SleepEasy?

If so, go to <http://sleepeasy.respironics.com/register> to register your product and receive your SleepEasy travel bag. A nominal charge for shipping and handling will be applied.

This SleepEasy device is covered by one or more of the following patents: U.S. Patent No. 6,622,724. Other U.S. and Foreign Patents Pending. © 2007 Respironics, Inc. and its affiliates. All rights reserved.

TABLE OF CONTENTS

Chapter 1: Introduction	1
1.1 System Contents	1
1.2 Intended Use	2
1.3 Warnings, Cautions, and Contraindications	2
1.3.1 Warnings	2
1.3.2 Cautions	4
1.3.3 Contraindications	4
1.4 System Overview	5
1.4.1 Breathing Circuit Overview	7
1.5 Glossary	7
1.6 Symbol Key	8
1.7 How to Contact Respirationics	8
Chapter 2: Device Controls and Displays	9
2.1 Control Buttons	9
2.2 Display	9
2.3 LED Backlight	10
2.4 Control Panel Inactivity	10
Chapter 3: Setup	11
3.1 Installing the Air Filters	11
3.2 Where to Place the Device	12
3.3 Connecting the Breathing Circuit	12
3.4 Supplying AC Power to the Device	14
3.5 Setup the Integrated Humidifier	14
3.6 Setup Example	16

Chapter 4: Device Operation	17
4.1 Starting the Device	17
4.2 Using the Ramp Feature.....	18
4.2.1 Ramp Feature.....	18
4.2.2 Setting Ramp	18
4.3 Using the Heated Humidifier Feature	19
4.3.1 Heated Humidifier Feature	19
4.3.2 Setting Heated Humidifier	19
4.4 Altitude Setting	19
4.5 Display Screens.....	20
4.5.1 Navigating the Display Screens.....	20
4.5.2 Viewing Data on the Patient Data Screens.....	20
4.6 System Error Screen	21
Chapter 5: Alerts and Troubleshooting	22
5.1 Device Alerts	22
5.2 Troubleshooting.....	22
Chapter 6: Accessories	25
6.1 Adding Supplemental Oxygen	25
6.2 Traveling with the System	26
6.2.1 International Travel.....	26
Chapter 7: Cleaning and Maintenance.....	27
7.1 Cleaning the Device	27
7.2 Cleaning or Replacing the Filters.....	27
7.3 Cleaning the Tubing	28
7.4 Cleaning the Water Chamber.....	28
7.5 Service	29
Chapter 8: Specifications.....	30
Appendix A: EMC Information.....	32

CHAPTER 1: INTRODUCTION

This chapter provides information on:

- SleepEasy system contents
- Intended Use
- Warnings, cautions, and contraindications
- System overview
- Glossary and symbol key
- How to contact Respirationics

1.1 SYSTEM CONTENTS

Your SleepEasy system includes the following items:

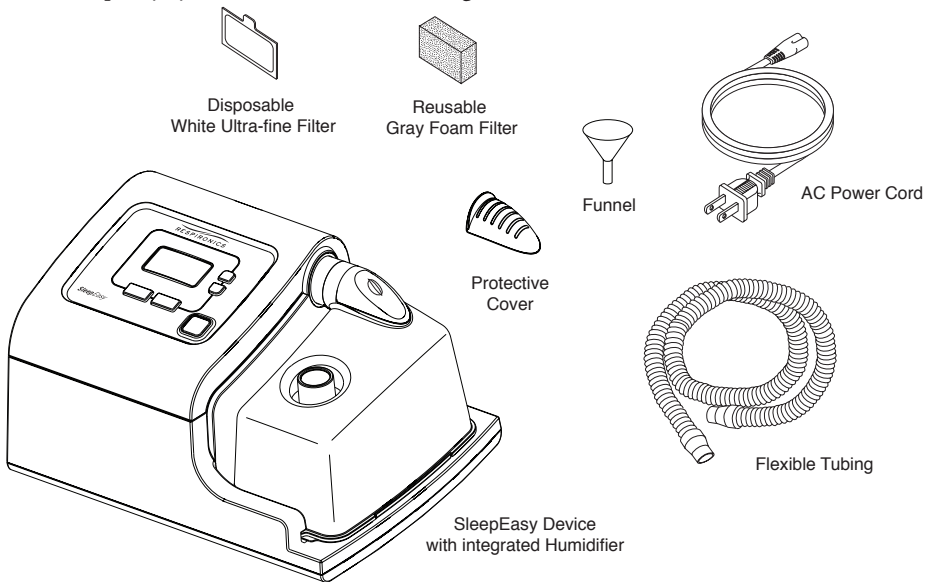

FIGURE 1-1 SYSTEM CONTENTS

NOTE: If any of the above items are missing, contact your home care provider.

1.2 INTENDED USE

The Respironics SleepEasy device delivers positive airway pressure therapy for the treatment of Obstructive Sleep Apnea in spontaneously breathing patients weighing >66 lbs. It is intended for use in the home or hospital environment.

Your home care provider will make the correct pressure settings according to your health care professional's prescription.

Several accessories are available to make your OSA treatment with the SleepEasy system as convenient and comfortable as possible. To ensure that you receive the safe, effective therapy prescribed for you, use only Respironics accessories.

1.3 WARNINGS, CAUTIONS, AND CONTRAINDICATIONS

CAUTION: U.S. federal law restricts this device to sale by or on the order of a physician.

Read all instructions before using the SleepEasy device with integrated humidifier.

1.3.1 WARNINGS

A warning indicates the possibility of injury to the user or the operator.

- This manual serves as a reference. The instructions in this manual are not intended to supersede the health care professional's instructions regarding the use of the device.
- The operator should read and understand this entire manual before using the device.
- This device is not intended for life support.
- The device should be used only with masks and connectors recommended by Respironics or with those recommended by the health care professional or respiratory therapist. A mask should not be used unless the device is turned on and operating properly. The exhalation port(s) associated with the mask should never be blocked.
Explanation of the Warning: The device is intended to be used with special masks or connectors that have exhalation ports to allow continuous flow of air out of the mask. When the device is turned on and functioning properly, new air from the device flushes the exhaled air out through the mask exhalation port. However, when the device is not operating, enough fresh air will not be provided through the mask, and exhaled air may be rebreathed. Rebreathing of exhaled air for longer than several minutes can in some circumstances lead to suffocation.
- Do not use this device without the water chamber in place.
- This device contains small parts which could present a choking hazard.
- Do not use extension cords with this device.
- If oxygen is used with the device, turn on the device before you turn on the oxygen flow. Also, the oxygen flow must be turned off when the device is not in use.
Explanation of the Warning: When the device is not in operation and the oxygen flow is left on, oxygen delivered into the tubing may accumulate within the device's enclosure. Oxygen accumulated in the device enclosure will create a risk of fire.
- Oxygen supports combustion. Oxygen should not be used while smoking or in the presence of an open flame.

- When using oxygen with this system, a Respiroics Pressure Valve must be placed in-line with the patient circuit. Failure to use the pressure valve could result in a fire hazard.
- Do not use the device in the presence of a flammable anaesthetic mixture in combination with oxygen or air, or in the presence of nitrous oxide.
- Do not use the device near a source of toxic or harmful vapors.
- Do not use this device if the room temperature is warmer than 95° F. If the device is used at room temperatures warmer than 95° F, the temperature of the airflow may exceed 106° F. This could cause irritation or injury to your airway.
- Do not operate the device in direct sunlight or near a heating appliance because these conditions can increase the temperature of the air coming out of the device.
- Contact your health care professional if symptoms of sleep apnea recur.
- If you notice any unexplained changes in the performance of this device, if it is making unusual or harsh sounds, or if the enclosure is broken, discontinue use and contact your home care provider.
- Repairs and adjustments must be performed by Respiroics-authorized service personnel only. Unauthorized service could cause injury, invalidate the warranty, or result in costly damage.
- Periodically inspect electrical cords and cables for damage or signs of wear. Discontinue use and replace if damaged.
- To avoid electric shock, unplug the device before cleaning it. DO NOT immerse the device in any fluids.
- Using this device at an incorrect altitude setting could result in airflow pressures higher or lower than the prescribed setting. Always verify the altitude setting when traveling or relocating, and adjust the system accordingly.
- Pins of connectors identified with the ESD warning symbol () should not be touched. Connections should not be made to these connectors unless ESD precautionary procedures are used. Precautionary procedures include methods to prevent build-up of electrostatic discharge (e.g., air conditioning, humidification, conductive floor coverings, non-synthetic clothing), discharging one's body to the frame of the equipment or system or to earth or a large metal object, and bonding oneself by means of a wrist strap to the equipment or system or to earth.
- Never operate the device if any of the parts are damaged, or if it is not working properly. Do not use the device if the water chamber is leaking or damaged in any way. Have any damaged parts replaced before continuing use.
- Never touch the heater plate unless the unit is unplugged and the plate has cooled down.
- While the device is in operation, the soft flap on the flapper valve must move freely and close off the opening on top of the water chamber. Replace the flapper valve if the flap is damaged or not intact.
- When installing the water chamber onto the system, do not allow any water to spill into the CPAP device.
- When installing the water chamber onto the system, make sure the soft valve is first attached to the water chamber.

1.3.2 CAUTIONS

A Caution indicates the possibility of damage to the device.

- The device may only be operated at temperatures between 41° F and 95° F.
- If this device has been exposed to either very hot or very cold temperatures, allow it to adjust to room temperature (operating temperature) before starting therapy. Do not operate the device outside of the operating temperature range shown in Chapter 8.
- Do not immerse the device or allow any liquid to enter the enclosure or the inlet filter.
- Do not place the device in or on any container that can collect or hold water.
- Make sure that the drain holes on the bottom of the device are not blocked.
- Condensation may damage the device. Always allow the device to reach room temperature before use.
- A properly installed, undamaged reusable foam inlet filter is required for proper operation.
- Tobacco smoke may cause tar build-up within the device, which may result in the device malfunctioning.
- If fluids are spilled onto the heater plate, unplug the power cord from the AC wall outlet and allow the device to drain and dry before using.
- Take precautions to protect furniture from water damage.
- Use distilled water only in the chamber.
- Do not fill water chamber above the fill line indicated on the side of the water chamber.
- Make sure the protective cover is securely fastened on top of the water chamber before operating the device.

NOTE: Additional warnings, cautions, and notes are located throughout this manual.

1.3.3 CONTRAINDICATIONS

When assessing the relative risks and benefits of using this equipment, the clinician should understand that this device can deliver pressures up to 20 cm H₂O. In the event of certain fault conditions, a maximum pressure of 35 cm H₂O is possible. Studies have shown that the following pre-existing conditions may contraindicate the use of CPAP therapy for some patients:

- Bullous Lung Disease
- Pathologically Low Blood Pressure
- Bypassed Upper Airway
- Pneumothorax
- Pneumocephalus has been reported in a patient using nasal Continuous Positive Airway Pressure. Caution should be used when prescribing CPAP for susceptible patients such as those with: cerebral spinal fluid (CSF) leaks, abnormalities of the cribriform plate, prior history of head trauma, and/or pneumocephalus. (Chest 1989; 96:1425-1426)

The use of positive airway pressure therapy may be temporarily contraindicated if you exhibit signs of a sinus or middle ear infection. Not for use with patients whose upper airways are bypassed. Contact your physician if you have any questions concerning your therapy.

1.4 SYSTEM OVERVIEW

The SleepEasy device, shown in Figure 1–2, is a sleep apnea system that delivers Continuous Positive Airway Pressure (CPAP). CPAP maintains a constant level of pressure throughout the breathing cycle.

Several accessories are also available for use with your SleepEasy device. Contact your home care provider to purchase any accessories not included with your system.

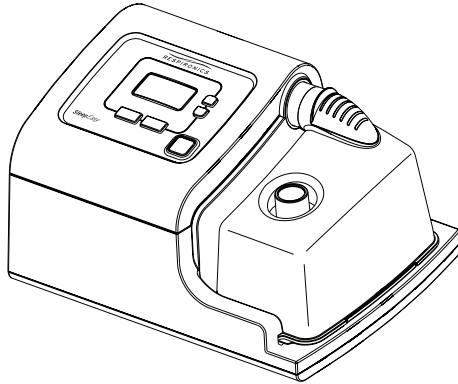

FIGURE 1–2 SLEEPEASY DEVICE

Figure 1–3 illustrates many of the device features, described in the following table.

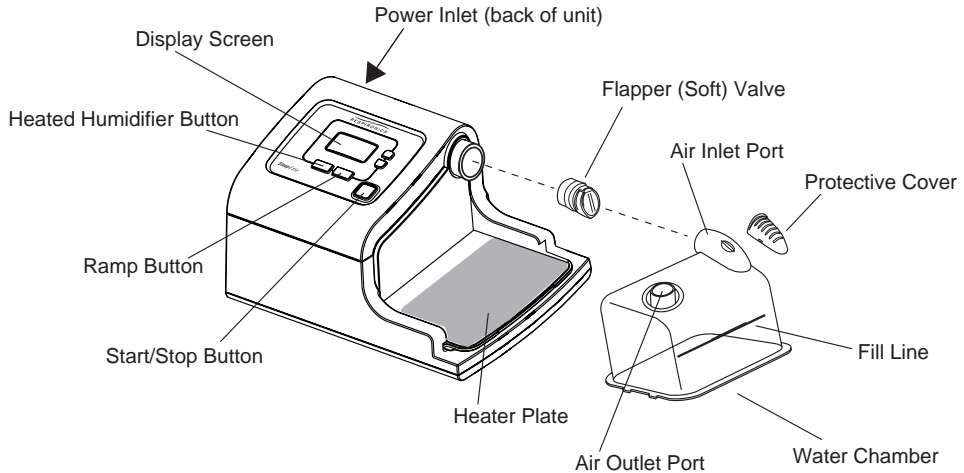

FIGURE 1–3 SYSTEM OVERVIEW

DEVICE FEATURE	DESCRIPTION
Display Screen	Shows therapy settings, patient data, and error messages.
Heated Humidifier Button	This button controls the humidifier functions.
Ramp Button	This button starts or restarts the ramp cycle.
Start/Stop Button	This button starts or stops the airflow and the heater plate (if activated).
Heater Plate	Warms the water in the water chamber.
Air Outlet Port	Connect the flexible tubing here.
Water Chamber	The removable water chamber holds the water for humidification.
Fill Line	This indicates the maximum water level for safe operation.
Protective Cover	Clip on top of the water chamber to prevent debris from entering the water chamber.
Flapper Valve	This valve helps prevent water from splashing into the device.
Power Inlet	Connect the power cord here.
Medical Equipment Note (bottom of unit)	For ease at airport security stations, there is a note on the bottom of the device stating that it is medical equipment. It may help if you also take this manual with you when you travel.
Filter Area (back of unit)	A reusable, gray foam filter must be placed in the filter area to screen out normal household dust and pollens. An optional, white ultra-fine filter can also be used for more complete filtration of very fine particles.

1.4.1 BREATHING CIRCUIT OVERVIEW

The patient breathing circuit, shown in Figure 1–4, consists of the following:

- Circuit tubing to deliver air from the device to your interface (e.g., mask)
- A mask or other patient interface device to deliver the prescribed pressure to your nose or nose and mouth, depending on which interface has been prescribed for you
- An exhalation device to vent exhaled air from the circuit

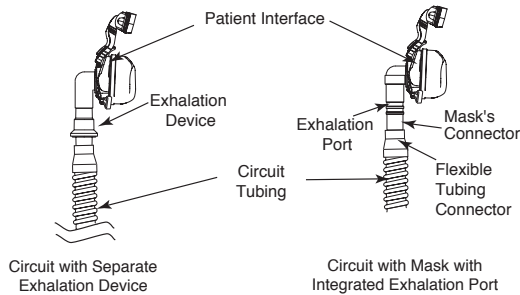

FIGURE 1–4 TYPICAL BREATHING CIRCUITS

NOTE: The exhalation port may be part of the interface or may be part of a separate exhalation device, but is required to minimize the potential for CO₂ rebreathing.









1.5 GLOSSARY

The following terms and acronyms appear throughout this manual:

TERM/ACRONYM	DEFINITION
Active State	The state of the device when power is applied, the airflow is on, and the device is providing therapy.
Apnea	A condition marked by the cessation of spontaneous breathing.
CPAP	Continuous Positive Airway Pressure
OSA	Obstructive Sleep Apnea
Ramp	A feature that may increase patient comfort when therapy is started. The ramp feature reduces pressure and then gradually increases the pressure to the prescription setting so you can fall asleep more comfortably.
Safe State	The state in which the device does not provide therapy. The device enters this state if an error is detected.
Standby State	The state of the device when power is applied but the airflow and humidification is turned off.

1.6 SYMBOL KEY

The following symbols appear on the device:

SYMBOL	DEFINITION
	Consult accompanying instructions for use.
	Type BF Applied Part
	Class II (Double Insulated)
IPX1	Drip Proof Equipment
	Electrostatic Discharge
	Canadian/US Safety Certification
	Hot Surface
	Caution
	Serial Interface
	Maximum Fill Line

1.7 HOW TO CONTACT RESPIRONICS

To have your device serviced, contact your home care provider. If you need to contact Respirationics directly, call the Respirationics Customer Service department at 1-800-345-6443 (US and Canada only) or 1-724-387-4000. You can also use the following address:

Respirationics

1001 Murry Ridge Lane

Murrysville, PA 15668

Visit Respirationics web site at: www.respirationics.com.

CHAPTER 2: DEVICE CONTROLS AND DISPLAYS

This chapter describes the device's control buttons and displays, patient circuit connections, and rear panel connections.

2.1 CONTROLS BUTTONS

Figure 2–1 shows the five primary control buttons on the SleepEasy device.

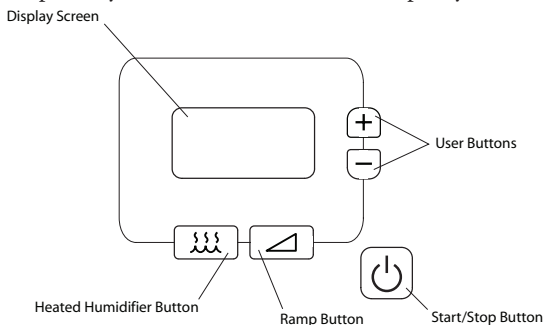







FIGURE 2–1 PRIMARY CONTROL BUTTONS

These buttons are described below.

BUTTON	DESCRIPTION
	Starts the airflow and places the device into Active state, or stops the airflow, and places the device into Standby state. It is also used to exit any display screen.
	Controls the humidifier functions.
	When the airflow is on, this button allows you to activate or restart the ramp function. Ramp lowers the airflow pressure and then gradually increases it, allowing you to fall asleep more easily.
	Performs next screen navigation or increases setting.
	Performs previous screen navigation or decreases setting.













2.2 DISPLAY

Figure 2–2 shows the display screen.



FIGURE 2–2 DISPLAY SCREEN

The information shown on the display screen is defined as follows:

ICON	DESCRIPTION
	Indicates that the Blower Hours or the User Hours Time Meter is being displayed.
	Indicates that the Therapy Hours Time Meter is being displayed.
	When displayed with the Therapy Hours icon, it indicates that the Session Counter is being displayed.
	Indicates that the Altitude Level is being displayed.
	Indicates that the humidifier is providing heat.
	Indicates that the unit is in the Provider Settings Menu.
	In Active State, indicates that the Ramp function is in progress. In menus, it is used to indicate Ramp Time Setting alone, or in combination with Ramp Start Pressure.
	Indicates that the Ramp Start Pressure is being displayed.
	Indicates that a pressure value is being displayed.
	Indicates that the user may erase the displayed data. Indicates that the unit requires user attention.
	Indicates that the unit requires user attention.
	Indicates that the Compliance Checksum for the unit is being displayed.

2.3 LED BACKLIGHT

The START/STOP, HEAT and RAMP buttons are lit by LED backlights. The START/STOP LED will always be on when power is applied to the device. The HEAT LED is on when the humidifier heater plate is active, and off when it is not. The RAMP LED is on when the ramp function is active and off when it is not.

2.4 CONTROL PANEL INACTIVITY

Some screens have time-out periods. The screen's timer starts when the screen is initially displayed and is restarted whenever a button is pressed. Unless otherwise specified, all screens timeout after one minute and will return to the Inactive Display. If in Provider Mode, the unit will additionally exit Provider Mode.

CHAPTER 3: SETUP

This chapter provides instructions on how to:

- Install the air filters
- Position the device
- Connect the breathing circuit
- Supply power to the device
- Setup the integrated humidifier

3.1 INSTALLING THE AIR FILTERS

CAUTION: A properly installed, undamaged foam filter is required for proper operation.

The device uses a gray foam filter that is washable and reusable, and an optional white ultra-fine filter that is disposable. The reusable filter screens out normal household dust and pollens, while the optional ultra-fine filter provides more complete filtration of very fine particles. The gray reusable filter must be in place at all times when the device is operating. The ultra-fine filter is recommended for people who are sensitive to tobacco smoke or other small particles.

A reusable gray foam filter and a disposable ultra-fine filter are supplied with the device.

If your filters are not already installed when you receive your device, you must at least install the reusable gray foam filter before using the device.

To install the filter(s):

1. If you are using the white disposable ultra-fine filter, insert it into the filter area first, mesh-side facing in, towards the device.
2. Insert the gray foam filter into the filter area as shown in Figure 3–1.

NOTE: If you are not using the white disposable filter, simply insert the gray foam filter into the filter area.

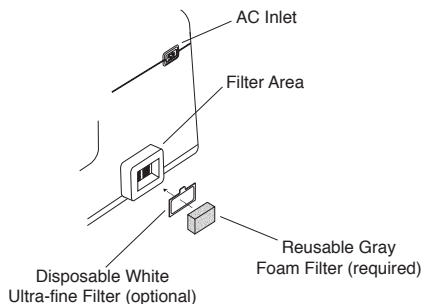

FIGURE 3–1 INSTALLING THE AIR FILTER

NOTE: See Chapter 7, Cleaning and Maintenance, for information on how to clean or replace the air filters.

3.2 WHERE TO PLACE THE DEVICE

Place the device on a firm, flat surface somewhere within easy reach of where you will use it at a level lower than your sleeping position. Make sure the filter area on the back of the device is not blocked by bedding, curtains, or other items. Air must flow freely around the device for the system to work properly. Make sure the device is away from any heating or cooling equipment (e.g., forced air vents, radiators, air conditioners).

CAUTION: Do not place the device directly onto carpet, fabric, or other flammable materials.

CAUTION: Do not place the device in or on any container that can collect or hold water.

CAUTION: Make sure that the drain holes on the bottom of the device are not blocked.

CAUTION: Take precautions to protect furniture from water damage.

CAUTION: Do not turn the device on without the water chamber installed.

3.3 CONNECTING THE BREATHING CIRCUIT

To use the system, you will need the following accessories in order to assemble the recommended circuit:

- Respironics interface (e.g, nasal mask or full face mask) with integrated exhalation port (or Respironics interface with a separate exhalation device such as the Whisper Swivel® II)
- Respironics 6 ft. flexible tubing
- Respironics headgear (for the patient interface)

WARNING: If the device is used by multiple persons (e.g., rental devices), a low-resistance, main flow bacteria filter should be installed in-line between the device and the circuit tubing to prevent contamination.

To connect your breathing circuit to the device, complete the following steps:

1. Connect the flexible tubing to the air outlet on the top of the device, as shown in Figure 3–2.

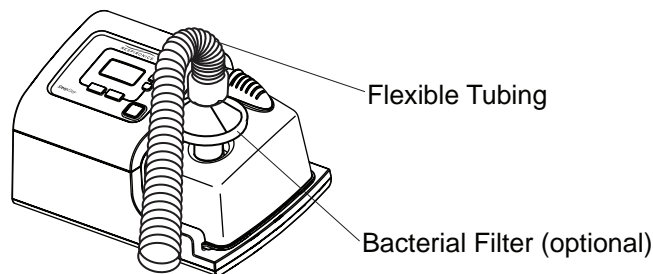

FIGURE 3–2 CONNECTING THE FLEXIBLE TUBING

NOTE: If required, connect a bacteria filter to the device air outlet, and then connect the flexible tubing to the outlet of the bacteria filter.

NOTE: The bacteria filter is recommended to protect the patient, care provider and equipment from the transference of a virus or bacteria through the breathing circuit.

2. Connect the tubing to the mask:
 - a. If you are using a mask with a built-in exhalation port, connect the mask's connector to the flexible tubing, as shown in Figure 3–3.

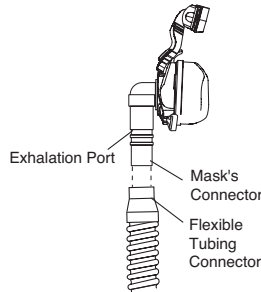

FIGURE 3–3 CONNECTING A MASK WITH BUILT-IN EXHALATION PORT

- b. If you are using a mask with a separate exhalation device, connect the open end of the flexible tubing to the exhalation device as shown in Figure 3–4. Position the exhalation device so that the vented air is blowing away from your face. Connect the mask's connector to the exhalation device.

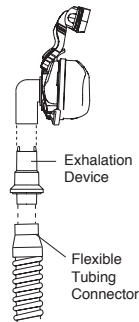

FIGURE 3–4 CONNECTING A MASK WITH A SEPARATE EXHALATION DEVICE

WARNING: The exhalation device (e.g., Whisper Swivel II) or exhalation port (on masks with an integrated exhalation port) is designed to exhaust CO₂ from the patient circuit. Do not block or seal the ports on the exhalation device.

WARNING: If you are using a full face mask (i.e., a mask covering both your mouth and your nose), the mask must be equipped with a safety (enainment) valve. You must ensure that the enainment valve is functioning properly.

3. Attach the headgear to the mask. See the instructions that came with your headgear.

3.4 SUPPLYING AC POWER TO THE DEVICE

CAUTION: If this device has been exposed to either very hot or very cold temperatures, allow it to adjust to room temperature (operating temperature) before beginning the following setup procedures. Do not operate the device outside of the operating temperature range shown in Chapter 8.

WARNING: Route the wires to avoid tripping.

WARNING: This device is activated when the power cord is connected. Pressing the  button turns the airflow and humidifier (if activated) on or off.

Complete the following steps to operate the device using AC power.

1. Plug the pronged end of the AC power cord into an electrical outlet that is not controlled by a wall switch.
2. Plug the power cord's connector into the power inlet on the back of the device, as shown in Figure 3-5.

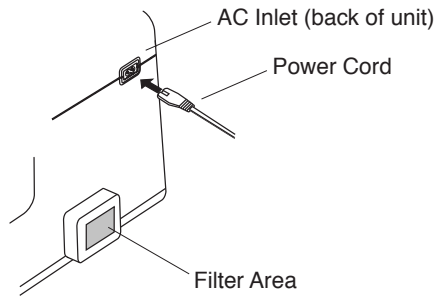

FIGURE 3-5 CONNECTING THE POWER CORD TO THE DEVICE

3. Ensure that all connections are secure.

IMPORTANT: To remove AC power, disconnect the power cord from the electrical outlet.

WARNING: Inspect the power cord often for any signs of damage. Replace a damaged power cord immediately.

WARNING: Do not use extension cords with this device.

3.5 SETUP THE INTEGRATED HUMIDIFIER

WARNING: Do not use the SleepEasy device without the water chamber in place.

FIRST USE

1. Slide the water chamber out from the side of the unit.

2. Gently remove the base of the chamber with your hands, being careful not to damage the rubber seal.
3. Remove the flapper valve from the air inlet port; unclip the protective cover from the top of the water chamber, as shown in Figure 3-6. Wash these parts by hand only in a solution of warm water and mild liquid dishwashing soap. Rinse the parts with clean water and allow them to air dry.

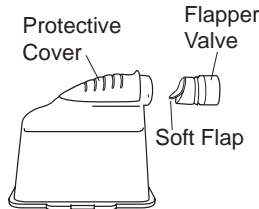

FIGURE 3-6 FLAPPER VALVE AND PROTECTIVE COVER

4. Wash the water chamber and heater plate in the dishwasher (top shelf only) or by hand in a solution of warm water and mild dishwashing soap.
5. Reassemble. Insert the flapper valve into the air inlet port, and clip the protective cover on top of the water chamber, as shown in Figure 3-6.
6. Fill the chamber to the fill line with distilled water.

CAUTION: Use only distilled water in the chamber.

7. Slide the chamber into place on the side of the unit. Continue as instructed in Step 5 of Daily Use.

DAILY USE

1. Slide the water chamber out from the side of the unit.
2. Before each use, check the flapper valve operation. Visually inspect the soft flap to make sure it is free to open and close when installed in the water chamber. Check to make sure the soft flap is not pushed back into the flapper valve. Replace the valve if the soft flap is damaged or missing. Make sure the protective cover is clipped into place on top of the water chamber.
3. Before each use, rinse the chamber with water. Fill the chamber to the fill line with distilled water using the funnel, as shown in Figure 3-7.

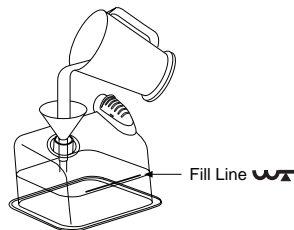

FIGURE 3-7 FILLING THE WATER CHAMBER

CAUTION: Use only distilled water in the chamber.

CAUTION: Do not overfill the water chamber. Damage to the therapy device may occur.

CAUTION: Do not allow the water chamber to sit for any length of time after it has been filled with water. Immediately install the chamber in the device (step 4). Allowing water to sit in the chamber (when the chamber is not installed in the device) may cause the chamber to separate from the bottom plate and may cause water leakage.

4. Slide the chamber into place on the side of the unit.

WARNING: Do not touch the heater plate with your hands.

CAUTION: Avoid moving the device when the water chamber has water in it.

5. Connect the flexible tubing (included with your therapy device system) to the outlet port on the water chamber.

IMPORTANT: Before each use, examine the flexible tubing for any kinks, damage, or debris. If necessary, clean the tubing to remove the debris. Replace any damaged tubing.

6. The ideal humidity setting depends on room temperature and humidity. Initially, a setting of 2 is recommended. You can adjust this setting at any time. Press and hold the humidifier button on the therapy device. The humidifier symbol and setting will appear. Press the + or - buttons to change the setting.

IMPORTANT: When the airflow is turned off, the humidifier will automatically shut off. If you restart the airflow, the heated humidification will return to the previous setting. Loss of power to the system will require the user to press the heated humidifier button to reactivate the humidifier.

3.6 SETUP EXAMPLE

Figure 3–8 shows an example of how you should route your tubing and situate your device on your night stand for the best setup possible. This will help prevent the device from falling off your night stand or table.

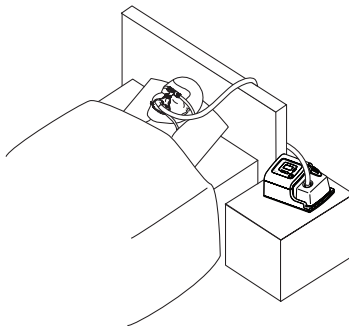

FIGURE 3–8 RECOMMENDED DEVICE AND TUBING PLACEMENT

CHAPTER 4: DEVICE OPERATION

This chapter explains how to start the device and change the settings.

NOTE: The numbers shown in the screens throughout this manual are examples only. Actual numbers will vary.

4.1 STARTING THE DEVICE

1. Plug the device in to an AC power source. The HEAT, RAMP and START/STOP buttons light up and the Software Version screen momentarily appears, shown in Figure 4–1.



FIGURE 4–1 SOFTWARE VERSION SCREEN

2. The next screen to appear is the Standby screen, shown in Figure 4–2. See Section 4.5 for instructions on how to navigate the display screens.

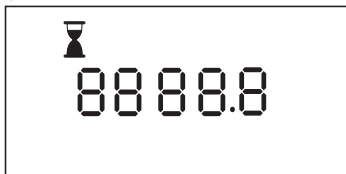

FIGURE 4–2 STANDBY SCREEN

3. Press the  button to turn on the airflow. The altitude setting screen will appear for approximately one second. Put on your mask assembly when the air starts to flow.
4. The Operate screen appears, shown in Figure 4–3.



FIGURE 4–3 OPERATE SCREEN

The Operate screen shows the current CPAP setting.

5. Make sure that no air is leaking from your mask into your eyes. If it is, adjust the mask and headgear until the air leak stops. See the instructions provided with your mask for more information.

NOTE: A small amount of mask leak is normal and acceptable. Correct large mask leaks or eye irritation from an air leak as soon as possible.

6. If you are using the device in bed, try placing the tubing from the device over your headboard. This may reduce tension on the mask.

NOTE: If you are having trouble with your mask, refer to the instructions supplied with the mask.

NOTE: You must remove the mask and patient circuit before you get out of bed.

4.2 USING THE RAMP FEATURE

You can press the RAMP  button to activate the Ramp feature, if your provider has enabled this feature.

4.2.1 RAMP FEATURE

The device is equipped with an optional ramp feature that your home care provider can enable or disable. This feature reduces the air pressure when you are trying to fall asleep and then gradually increases (ramps) the pressure until your prescription setting is reached, allowing you to fall asleep more comfortably.

If ramp is enabled on your device, after you turn on the airflow, press the RAMP button on the top of the device. You can use the RAMP button as often as you wish during the night.

NOTE: If the ramp feature is disabled, nothing will happen when you press the RAMP button.

4.2.2 SETTING RAMP

This screen is entered by pressing and holding the RAMP  button for 3 seconds. The Ramp Starting Pressure Screen will appear, Figure 4-4. It can be entered from either the standby or operate screen.

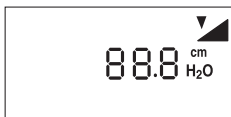



FIGURE 4-4 RAMP STARTING PRESSURE SCREEN

You can increase or decrease the ramp starting pressure in 0.5 cm H₂O increments by pressing the + or – buttons. The default setting is 4 cm H₂O. You can adjust the setting from 4 cm H₂O to the CPAP pressure setting.

NOTE: This screen will not display if your provider has not enabled Ramp on your device.

After you have finished modifying this screen, press the  button to return to the Standby screen.

4.3 USING THE HEATED HUMIDIFIER FEATURES

4.3.1 HEATED HUMIDIFIER FEATURE

The Integrated Heated Humidifier is a feature that may reduce nasal dryness and irritation by adding moisture and heat to the airflow. This feature can be enabled or disabled by your home care provider.

4.3.2 SETTING HEATED HUMIDIFIER

If the heated humidifier is enabled on your device, press the HEAT  button on the top of the device. The Heat Setting screen will appear, Figure 4-5. You can enter this screen from either the standby or operate screen.

NOTE: If the heated humidifier feature is disabled by the home care provider, nothing will happen when you press the HEAT button.





FIGURE 4-5 HEAT SETTING SCREEN

You can increase or decrease the humidifier heat settings by pressing the + or – buttons. The possible settings are from 0 (off) to 5 which is the highest setting.

NOTE: This screen will not display if your provider has not enabled the humidifier on your device.

After you have finished modifying this screen, press the  button to return to the Standby screen.

4.4 ALTITUDE SETTING

To access the Altitude Setting screen, you press and hold both the RAMP  button and the HEAT  button simultaneously for 3 seconds. The Altitude Setting screen will then appear, Figure 4-6.

NOTE: You can only enter this screen from the standby screen.

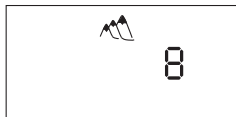

FIGURE 4-6 ALTITUDE SETTING SCREEN

This screen allows you to modify the altitude adjustment setting. Press the + or – buttons to increase or decrease the setting by increments of 1:

- 1 = less than <2500 ft.
- 2 = 2500 ft. to 5000 ft.
- 3 = 5000 ft. to 7500 ft.

NOTE: Elevations over 7500 ft. may affect the accuracy of the pressure.

WARNING: If you incorrectly set the manual altitude setting, the pressure may be too high or too low, depending on your location.

4.5 DISPLAY SCREENS

You can view the set pressure on the Active Display screen (Operate screen), as well as the following information on the Patient Data screens:

- Therapy usage hours (standby screen)
- Blower hours
- Number of sessions greater than 4 hours
- Compliance checksum
- Current altitude setting

4.5.1 NAVIGATING THE DISPLAY SCREENS

Use the + and - buttons to navigate the display screens.

NOTE: You can only enter these screens from the standby screen.

4.5.2 VIEWING DATA ON THE PATIENT DATA SCREENS

The following describes the Patient Data screens.

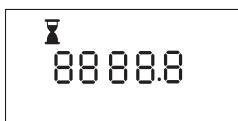

1. Therapy Usage Hours (Standby Screen)

This screen displays the amount of time that the device provided therapy (with the blower on and the patient connected). The decimal digit is displayed if user hours are less than 10000 so it can be displayed with 0.1 hour resolution. Otherwise, the values between 10000 and 99999 hours can be displayed.

Note: *This screen is only for reference. Your home care provider may periodically ask you for this information.*

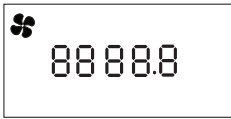

2. Blower Hours Screen

This screen displays the amount of time that the blower has been active over the life of the device. The decimal digit is displayed if user hours are less than 10000 so it can be displayed with 0.1 hour resolution. Otherwise, the values between 10000 and 99999 hours can be displayed.

Note: *This screen is only for reference. Your home care provider may periodically ask you for this information.*



3. Session Counter Screen

This screen displays the number of device therapy sessions that exceeded 4 hours.

Note: *This screen is only for reference. Your home care provider may periodically ask you for this information.*

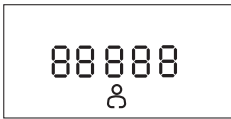

4. Compliance Check Screen

This screen shows you the Compliance Check Value.

Note: *Your home care provider may periodically ask you for this information.*



5. Altitude Setting Screen

This screen shows you the current altitude adjustment setting. The value will either be 1, 2 or 3:

- 1 = less than <2500 ft.
- 2 = 2500 ft. to 5000 ft.
- 3 = 5000 ft. to 7500 ft.

4.6 SYSTEM ERROR SCREEN

When the unit detects a system error, the System Error screen is displayed as shown in Figure 4-7. The blower is turned off and pushbutton functions are disabled. Refer to Chapter 5: Alerts and Troubleshooting for more information.



FIGURE 4-7 SYSTEM ERROR SCREEN

CHAPTER 5: ALERTS AND TROUBLESHOOTING

This chapter describes the device alerts and also provides troubleshooting information for issues you may run into when using the device.

5.1 DEVICE ALERTS

The device provides two alert levels, high and medium priority.

- **High Priority** – These alerts require immediate operator response. The alert signal is the backlights on the buttons providing a high priority flashing pattern consisting of a continuous, bright-to-off, two-flash pattern (indicated in the following table as: $\diamond\diamond$ $\diamond\diamond$ $\diamond\diamond$).

ALERT SUMMARY TABLE





The following table summarizes the priority alerts.

ALERT	VISUAL INDICATOR	DEVICE ACTION	POSSIBLE CAUSE	PATIENT ACTION
System Error	<p>Backlights: $\diamond\diamond$ $\diamond\diamond$ $\diamond\diamond$</p> <p>The following symbol displays to indicate that service is required:</p> 	The device enters the "Safe state" in which the device power remains on, but the airflow is disabled and the humidifier is turned off.	Device failure	Remove the power supply cord from the device to remove power. Plug the cord back into the device's power inlet to restore power. If the alert continues to occur, contact your home care provider.

5.2 TROUBLESHOOTING

The table below lists some of the problems you may experience with your device or mask and possible solutions to those problems.

PROBLEM	WHY IT HAPPENED	WHAT TO DO
Nothing happens when you apply power to the device. The backlights on the buttons do not light.	There's no power at the outlet or the device is unplugged.	If you are using AC power, check the outlet power and verify that the device is properly plugged in. Make sure the AC power cord is connected correctly to the power supply and the power supply cord is securely connected to the device's power inlet. If the problem continues to occur, contact your home care provider. Return the device to your provider, so they can determine if the problem is with the device.

PROBLEM	WHY IT HAPPENED	WHAT TO DO
<p>The device does not operate when you press the  button. The airflow does not turn on.</p>	<p>There may be a problem with the blower.</p>	<p>Make sure the device is powered correctly. If the button backlights turn on when you apply power, but the airflow does not turn on, there may be a problem with your device. Contact your home care provider for assistance.</p> <p>Note: <i>When the device is functioning correctly, after you press the  button, the airflow turns on after a slight delay. This brief delay is normal.</i></p>
<p>The device's display is erratic.</p>	<p>The device has been dropped or mishandled, or the device is in an area with high Electromagnetic Interference (EMI) emissions.</p>	<p>Unplug the device. Reapply power to the device. If the problem continues, relocate the device to an area with lower EMI emissions (e.g., away from electronic equipment such as cellular phones, cordless phones, computers, TVs, electronic games, hair dryers, etc.).</p> <p>If the problem still occurs, contact your home care provider for assistance.</p>
<p>Device Resets/Reboots:</p> <p>The device shuts down and restarts automatically during therapy. (This is unlikely to occur.)</p>	<p>The device comes installed with troubleshooting software that automatically monitors performance.</p>	<p>Such a reset poses no danger to the patient and assures that the patient receives prescribed therapy throughout the night. If there is a possibility of damage to the device, the device will shut down permanently. The product will then display the following system error alert symbol to indicate that the device be returned to the home care provider for service: </p>
<p>The Ramp feature does not work when you press the Ramp button .</p>	<p>Your home care provider did not prescribe Ramp for you, or your CPAP pressure is already set to the minimum setting.</p>	<p>If Ramp has not been prescribed for you, discuss this feature with your home care provider to see if they will change your prescription.</p> <p>If your provider has enabled Ramp, but the feature still does not work, check the CPAP setting on your Active Display screen. If CPAP is set to the minimum setting (4.0 cm H₂O), or the starting pressure is the same as the prescribed pressure, the Ramp feature will not work.</p>
<p>The air out of the mask is much warmer than usual.</p>	<p>The air filters may be dirty.</p> <p>The device may be operating in direct sunlight or near a heater.</p>	<p>Clean or replace the air filters as described in Chapter 7.</p> <p>The temperature of the air may vary somewhat based on your room temperature. Make sure that the device is properly ventilated. Keep the device away from bedding or curtains that could block the flow of air around the device. Make sure the device is away from direct sunlight and heating equipment.</p> <p>If the problem continues, contact your home care provider.</p>

PROBLEM	WHY IT HAPPENED	WHAT TO DO
The device has fallen off your table or night stand.	The device may not have been properly seated on the night stand, or the placement of the tubing may have caused the device to fall.	<p>Always make sure your device is placed on a hard, flat surface so the rubber feet on the bottom of the device can adhere to the surface (make sure there is no fabric under the device). The device must be level for proper operation.</p> <p>Also, place the device away from the edge of the night stand or table, so it doesn't accidentally get knocked off the table.</p> <p>Make sure that the device with humidifier is placed below your head and mask, so that any condensation in the tubing drains back into the water chamber.</p> <p>If the device with humidifier fall and water gets into the device, drain all water out of the device and make sure it is completely dry before reapplying power.</p> <p>If the placement of the tubing causes the device to fall, make sure that you use proper hose management when setting up your device. Route the tubing behind the bed's headboard, as shown in Chapter 3, Setup.</p> <p>If the device falls or water gets into the device upon falling, let the device dry completely before restarting it. If the device does not operate correctly after falling, contact your home care provider.</p>
Air leaks from the vent hole on top of the water chamber.	<p>Improperly assembled flapper (soft) valve.</p> <p>Damaged soft valve.</p>	<p>Remove water chamber and ensure that the flap of the valve operates freely. Reassemble system.</p> <p>Replace soft valve.</p>
The mask feels uncomfortable to wear, there is significant air leakage around the mask, or you experience other mask-related issues.	This could be due to improper headgear adjustment or improper mask fitting, etc.	If you experience any issues with your mask, refer to your mask instructions for information on proper fitting, etc. If the problem continues, contact your home care provider.
You have a runny nose.	This is caused by a nasal reaction to the airflow.	Call your health care professional.
You have throat or nose dryness.	The air is too dry.	Increase the room humidity. When using the humidifier, refer to the instructions to make sure the humidifier is working properly.
You experience nasal, sinus, or ear pain.	You may have a sinus or middle ear infection.	Stop using the device and contact your health care professional.

CHAPTER 6: ACCESSORIES

Contact your home care provider for additional information on the accessories available for your SleepEasy system. When using optional accessories, always follow the instructions enclosed with the accessories.

6.1 ADDING SUPPLEMENTAL OXYGEN

Oxygen may be added at the mask connection, as shown in Figure 6-1. Please note the warnings listed below when using oxygen with the device.

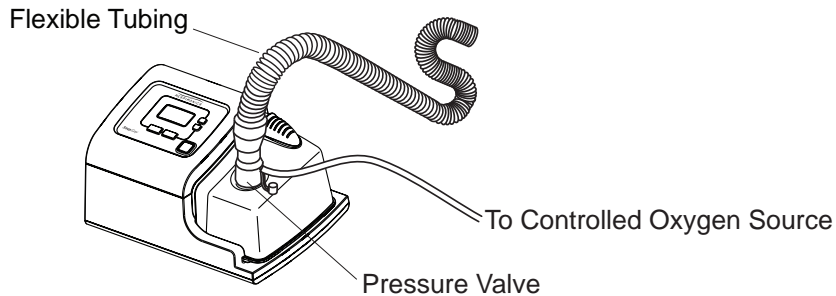

FIGURE 6-1 RESPIRONICS PRESSURE VALVE WITH OXYGEN EXAMPLE

WARNINGS

- When using oxygen with this system, the oxygen supply must comply with local regulations for medical oxygen.
- When using oxygen with this system, a Respiration Pressure Valve must be placed in-line with the patient circuit. Failure to use the pressure valve could result in a fire hazard.
- Oxygen accelerates fires. Keep the device and the oxygen container away from heat, open flames, any oily substance, or other sources of ignition. Do not smoke in the area near the device or the oxygen.
- When using oxygen with this system, turn the device on before turning on the oxygen. Turn the oxygen off before turning the device off. This will prevent oxygen accumulation in the device.
- If administering fixed-flow supplemental oxygen, the oxygen concentration may not be constant. The inspired oxygen concentration will vary, depending on the CPAP setting, patient breathing pattern, and leak rate. Substantial leaks around the mask may reduce the inspired oxygen concentration to less than the expected concentrations. Appropriate patient monitoring should be implemented.

6.2 TRAVELING WITH THE SYSTEM

For your convenience at security stations, there is a note on the bottom of the device stating that it is medical equipment. It may be helpful to bring this manual along with you to help security personnel understand the SleepEasy device. A travel bag is available as an accessory for the SleepEasy device. Contact Respironics to find out more information on the travel bag.

NOTE: Before traveling, you must completely empty and dry the water chamber.

NOTE: The water chamber must be detached from the unit while traveling.

NOTE: Make sure the soft valve is safely secured to protect from any damage that may occur while traveling.

6.2.1 INTERNATIONAL TRAVEL

If you are traveling to a country with a line voltage different than the one you are currently using, a different power cord or an international plug adaptor may be required to make your power cord compatible with the power outlets of the country to which you are traveling. Contact your home care provider for additional information.

CHAPTER 7: CLEANING AND MAINTENANCE

This chapter describes how to clean the device and its filters and provides tips on traveling with your SleepEasy system.

7.1 CLEANING THE DEVICE

WARNING: To avoid electrical shock, always unplug the power cord from the wall outlet before cleaning the device.

CAUTION: Do not immerse the device in liquid or allow any liquid to enter the enclosure, inlet filter, or any opening.

1. Unplug the device, and wipe the outside of the device with a cloth slightly dampened with water and a mild detergent. Let the device dry completely before plugging in the power cord.
2. Inspect the device and all circuit parts for damage after cleaning. Replace any damaged parts.

7.2 CLEANING OR REPLACING THE FILTERS

CAUTION: Operating the device with a dirty filter may keep the system from working properly and may damage the device.

Under normal usage, you should clean the gray foam filter at least once every two weeks and replace it with a new one every six months. The white ultra-fine filter is disposable and should be replaced after 30 nights of use or sooner if it appears dirty. **DO NOT** clean the ultra-fine filter.

CAUTION: Dirty inlet filters may cause high operating temperatures that may affect device performance. Regularly examine the inlet filters as needed for integrity and cleanliness.

1. If the device is operating, stop the airflow by pressing the  button. Disconnect the device from the power source.
2. Remove the filter(s) from the enclosure by gently squeezing the filter in the center and pulling it away from the device.
3. Examine the filter(s) for cleanliness and integrity.
4. Wash the gray foam filter in warm water with a mild detergent. Rinse thoroughly to remove all detergent residue. Allow the filter to air dry completely before reinstalling it. If the foam filter is torn, replace it. (Only Respironics-supplied filters should be used as replacement filters.)
5. If the white ultra-fine filter is dirty or torn, replace it.
6. Reinstall the filters, inserting the white ultra-fine filter first if applicable, refer to chapter 3.

CAUTION: Never install a wet filter into the device. You must ensure sufficient drying time for the cleaned filter.

7.3 CLEANING THE TUBING

Clean the tubing daily. Disconnect the flexible tubing from the device. Gently wash the tubing in a solution of warm water and a mild detergent. Rinse thoroughly. Air dry.

7.4 CLEANING THE WATER CHAMBER

Refer to Figure 7-1 when cleaning the water chamber.

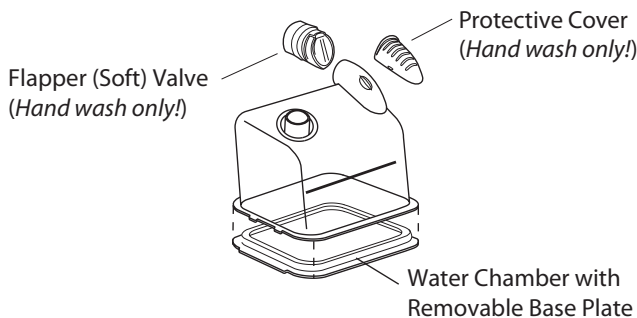

FIGURE 7-1 CLEANING THE WATER CHAMBER

NOTE: The Flapper (Soft) Valve has a one year lifespan. You must replace this valve after one year.

NOTE: Hand washing can be performed daily. Dishwashing can be performed once a week.

WARNING: Empty and clean the water chamber daily to prevent mold and bacteria growth.

WARNING: Allow the water in the chamber to cool to room temperature before removing the chamber from the humidifier.

1. Turn the therapy device off and allow approximately 15 minutes for the heater plate and water to cool.
2. Disconnect the tubing from the water chamber.
3. Slide the water chamber out of the humidifier platform. Empty any remaining water.
4. Gently remove the base of the chamber with your hands, being careful not to damage the rubber seal.
5. Remove the flapper valve from the air inlet port; unclip the protective cover from the top of the water chamber. *Wash these two parts by hand only in a solution of warm water and mild dishwashing soap.* Rinse with clean water and allow them to air dry.

6. Wash the water chamber and base plate in the dishwasher (top shelf only) or by hand in a solution of warm water and mild dishwashing soap.
7. Inspect all parts for damage prior to reassembly.
8. Reassemble the water chamber. Make sure the base plate is fully seated on the water chamber. Also, make sure you install the flapper valve properly into the air inlet port of the water chamber. See Figure 7-1.

NOTE: Be sure to reinstall the protective cover on top of the water chamber to prevent debris from entering the water chamber.

9. Fill the water chamber to the fill line. Inspect the water chamber for any leaks or damage. Replace the water chamber if any damage is present.

7.5 SERVICE

The SleepEasy device does not require routine servicing.

WARNING: If you notice unexplained changes in the performance of this device, if it is making unusual or harsh sounds, if the enclosure is broken, or if water has entered the device, discontinue use, and contact your home care provider.

CHAPTER 8: SPECIFICATIONS

ENVIRONMENTAL

	OPERATING	STORAGE
TEMPERATURE	41° F to 95° F	-4° F to 140° F
RELATIVE HUMIDITY	15 to 95% (non-condensing)	15 to 95% (non-condensing)
ATMOSPHERIC PRESSURE	77 to 101 kPa (0 - 7500 ft)	N/A

PHYSICAL

Dimensions: 10” L x 7.5” W x 5.5” H (25 x 19 x 14 cm)
 Weight: Approximately 3.5 lbs
 Water Capacity: 350 ml at recommended water level

STANDARDS COMPLIANCE

This device is designed to conform to the following standards:

- IEC 60601-1 General Requirements for Safety of Medical Electrical Equipment
- EN ISO 17510-1 Sleep Apnea Breathing Therapy Devices
- EN ISO 8185 General Requirements for Humidification Systems

ELECTRICAL

AC Power Consumption: 100 – 240 VAC, 50/60 Hz, 2.7 A max.
 Type of Protection Against Electric Shock: Class II Equipment
 Degree of Protection Against Electric Shock: Type BF Applied Part
 Degree of Protection against Ingress of Water: Device: Drip Proof, IPX1
 Mode of Operation: Continuous
 Electromagnetic Compatibility: The device meets the requirements of EN 60601-1-2, 2nd edition.
 Heater Settings:
 0 = off
 1 = 113° F
 2 = 122° F
 3 = 131° F
 4 = 140° F
 5 = 149° F
 LED Type: Type 1 per IEC 60825-1.
 Fuses: There are no user-replaceable fuses.

HUMIDITY

Humidity Range: 10 to 40 mg H₂O/L

PRESSURE

Pressure Increments: 4.0 to 20.0 cm H₂O (in 0.5 cm H₂O increments)

Pressure Stability: 4.0 to 20 cm H₂O (±1.0 cm H₂O)

Measured in accordance with EN ISO 17510-1 @ 1/3, 2/3, and Pmax with BPM set to 10, 15, and 20 BPM @ 20° C (±5° C), 50% RH (±5%).

Maximum Flow: 35 LPM

Measured in accordance with EN ISO 17510-1 @ Pmin, 1/4, 2/4, 3/4 and Pmax with BPM set to 4, 8, 12, 16, and 20 BPM @ 23° C (±2° C), 50% RH (±5%).

CONTROL ACCURACY

PARAMETER	RANGE	ACCURACY
CPAP	4 to 20 cm H ₂ O	± 1.0 cm H ₂ O or 10% (whichever is greater) from static setpoint* for all altitude settings.

* Measured at the patient end of the circuit with a Whisper Swivel II exhalation device and no patient flow.

DISPOSAL

Dispose of the device in accordance with local regulations.

APPENDIX A: EMC INFORMATION

GUIDANCE AND MANUFACTURER'S DECLARATION - ELECTROMAGNETIC EMISSIONS – This device is intended for use in the electromagnetic environment specified below. The user of this device should make sure it is used in such an environment.

EMISSIONS TEST	COMPLIANCE	ELECTROMAGNETIC ENVIRONMENT - GUIDANCE
RF emissions CISPR 11	Group 1	The device uses RF energy only for its internal function. Therefore, its RF emissions are very low and are not likely to cause any interference in nearby electronic equipment.
RF emissions CISPR 11	Class B	The device is suitable for use in all establishments, including domestic establishments and those directly connected to the public low-voltage power supply network.
Harmonic emissions IEC 61000-3-2	Class A	
Voltage fluctuations/Flicker emissions IEC 61000-3-3	Complies	

GUIDANCE AND MANUFACTURER'S DECLARATION - ELECTROMAGNETIC IMMUNITY – This device is intended for use in the electromagnetic environment specified below. The user of this device should make sure it is used in such an environment.

IMMUNITY TEST	IEC 60601 TEST LEVEL	COMPLIANCE LEVEL	ELECTROMAGNETIC ENVIRONMENT - GUIDANCE
Electrostatic Discharge (ESD) IEC 61000-4-2	±6 kV contact ±8 kV air	±6 kV contact ±8 kV air	Floors should be wood, concrete or ceramic tile. If floors are covered with synthetic material, the relative humidity should be at least 30%.
Electrical fast Transient/burst IEC 61000-4-4	±2 kV for power supply lines ±1 kV for input-output lines	±2 kV for supply mains ±1 kV for input/output lines	Mains power quality should be that of a typical home or hospital environment.
Surge IEC 61000-4-5	±1 kV differential mode ±2 kV common mode	±1 kV differential mode ±2 kV for common mode	Mains power quality should be that of a typical home or hospital environment.
Voltage dips, short interruptions and voltage variations on power supply input lines IEC 61000-4-11	<5% U_T (>95% dip in U_T) for 0.5 cycle 40% U_T (60% dip in U_T) for 5 cycles 70% U_T (30% dip in U_T) for 25 cycles <5% U_T (>95% dip in U_T) for 5 sec	<5% U_T (>95% dip in U_T) for 0.5 cycle 40% U_T (60% dip in U_T) for 5 cycles 70% U_T (30% dip in U_T) for 25 cycles <5% U_T (>95% dip in U_T) for 5 sec	Mains power quality should be that of a typical home or hospital environment. If the user of the device requires continued operation during power mains interruptions, it is recommended that the device be powered from an uninterruptible power supply or a battery.
Power frequency (50/60 Hz) magnetic field IEC 61000-4-8	3 A/m	3 A/m	Power frequency magnetic fields should be at levels characteristic of a typical location in a typical hospital or home environment.
NOTE: U_T is the a.c. mains voltage prior to application of the test level.			

GUIDANCE AND MANUFACTURER'S DECLARATION - ELECTROMAGNETIC IMMUNITY – This device is intended for use in the electromagnetic environment specified below. The user of this device should make sure it is used in such an environment.

IMMUNITY TEST	IEC 60601 TEST LEVEL	COMPLIANCE LEVEL	ELECTROMAGNETIC ENVIRONMENT –GUIDANCE
<p>Conducted RF IEC 61000-4-6</p> <p>Radiated RF IEC 61000-4-3</p>	<p>3 Vrms 150 kHz to 80 MHz</p> <p>3 V/m 80 MHz to 2.5 GHz</p>	<p>3 Vrms</p> <p>3 V/m</p>	<p>Portable and mobile RF communications equipment should be used no closer to any part of the device, including cables, than the recommended separation distance calculated from the equation applicable to the frequency of the transmitter.</p> <p>Recommended separation distance $d = 1.2 \sqrt{P}$</p> <p>$d = 1.2 \sqrt{P}$ 80 MHz to 800 MHz $d = 2.3 \sqrt{P}$ 800 MHz to 2.5 GHz</p> <p>where P is the maximum output power rating of the transmitter in watts (W) according to the transmitter manufacturer and d is the recommended separation distance in meters (m).</p> <p>Field strengths from fixed RF transmitters, as determined by an electromagnetic site survey^a, should be less than the compliance level in each frequency range.^b</p> <p>Interference may occur in the vicinity of equipment marked with the following symbol: </p>
<p>NOTE 1 At 80 MHz and 800 MHz, the higher frequency range applies.</p> <p>NOTE 2 These guidelines may not apply in all situations. Electromagnetic propagation is affected by absorption and reflection from structures, objects, and people.</p> <p>a Field strengths from fixed transmitters, such as base stations for radio (cellular/cordless) telephones and land mobile radios, amateur radio, AM and FM radio broadcast and TV broadcast cannot be predicted theoretically with accuracy. To assess the electromagnetic environment due to fixed RF transmitters, an electromagnetic site survey should be considered. If the measured field strength in the location in which the device is used exceeds the applicable RF compliance level above, the device should be observed to verify normal operation. If abnormal performance is observed, additional measures may be necessary, such as re-orienting or relocating the device.</p> <p>b Over the frequency range 150 kHz to 80 MHz, the field strengths should be less than 3 V/m.</p>			

RECOMMENDED SEPARATION DISTANCES BETWEEN PORTABLE AND MOBILE RF COMMUNICATIONS EQUIPMENT AND THIS DEVICE:

The device is intended for use in an electromagnetic environment in which radiated RF disturbances are controlled. The customer or the user of this device can help prevent electromagnetic interference by maintaining a minimum distance between portable and mobile RF communications equipment (transmitters) and this device as recommended below, according to the maximum output power of the communications equipment.

RATED MAXIMUM POWER OUTPUT OF TRANSMITTER W	SEPARATION DISTANCE ACCORDING TO FREQUENCY OF TRANSMITTER M		
	150 kHz TO 80 MHz $d = 1.2 \sqrt{P}$	80 MHz TO 800 MHz $d = 1.2 \sqrt{P}$	800 MHz TO 2.5 GHz $d = 2.3 \sqrt{P}$
0.01	0.12	0.12	0.23
0.1	0.38	0.38	0.73
1	1.2	1.2	2.3
10	3.8	3.8	7.3
100	12	12	23

For transmitters rated at a maximum output power not listed above, the recommended separation distance d in meters (m) can be estimated using the equation applicable to the frequency of the transmitter, where P is the maximum output power rating of the transmitter in watts (W) according to the transmitter manufacturer.

Note 1: At 80 MHz and 800 MHz, the separation distance for the higher frequency range applies.

Note 2: These guidelines may not apply in all situations. Electromagnetic propagation is affected by absorption and reflection from structures, objects, and people.

LIMITED WARRANTY

Respironics, Inc. warrants that the system shall be free from defects of workmanship and materials and will perform in accordance with the product specifications for a period of two (2) years from the date of sale by Respironics, Inc. to the dealer. If the product fails to perform in accordance with the product specifications, Respironics, Inc. will repair or replace – at its option – the defective material or part. Respironics, Inc. will pay customary freight charges from Respironics, Inc. to the dealer location only. This warranty does not cover damage caused by accident, misuse, abuse, alteration, and other defects not related to material or workmanship.

Respironics, Inc. disclaims all liability for economic loss, loss of profits, overhead, or consequential damages which may be claimed to arise from any sale or use of this product. Some states do not allow the exclusion or limitation of incidental or consequential damages, so the above limitation or exclusion may not apply to you.

This warranty is given in lieu of all other express warranties. In addition, any implied warranties – including any warranty of merchantability or fitness for the particular purpose – are limited to two years. Some states do not allow limitations on how long an implied warranty lasts, so the above limitation may not apply to you. This warranty gives you specific legal rights, and you may also have other rights which vary from state to state.

To exercise your rights under this warranty, contact your local authorized Respironics, Inc. dealer or contact Respironics, Inc. at:

1001 Murry Ridge Lane
Murrysville, Pennsylvania 15668-8550
1-724-387-4000



1001 Murry Ridge Lane
Murrysville, PA 15668
www.respironics.com

1047164
JR 11/20/07